

V1.1

Using a 32-bit motor driver chip and Field-Oriented Control (FOC), the RoboMaster C300 Brushless DC Motor Speed Controller enables precise control over motor torque.

Especially designed for the RoboMaster M3000 PMS Brushless DC Motor Starter and C300 Brushless DC Motor Speed Controller, the M3000 Assembly Kit includes universal pads and a terminal board.

Reference System Specification Manual, Reference System User Manual, Introduction of Reference System Kit

The M3000 Assembly Kit includes universal pads and a terminal board, ensuring a complete protection system for your RoboMaster system.



ROBOMASTER

ROBOMASTER 2020

AI CHALLENGE

RULES MANUAL

Prepared by the RoboMaster Organizing Committee

Updated on **January, 2020**

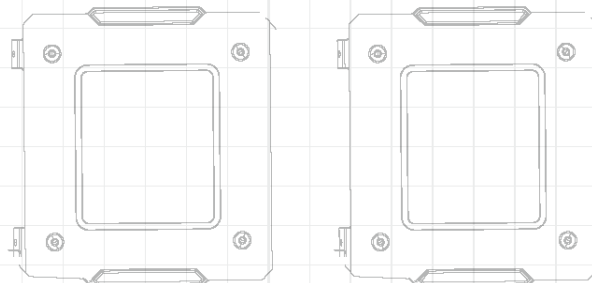

Statement

The RoboMaster Organizing Committee (hereinafter referred to as the "RMOC") encourages and advocates technological innovations and an open source of technology. We respect the intellectual property of the participating teams. All rights related to the intellectual property developed during the competition are owned by individual teams. The RoboMaster Organizing Committee will not participate in the handling of intellectual property disputes within the team. The participating teams must properly handle all aspects of intellectual property rights among internal school members, company members and other members of the team.

While using the robots, referee system and other competition materials provided by the RoboMaster Organizing Committee, all teams shall respect the ownership of all intellectual property. Teams are also prohibited from engaging in any behavior that violates intellectual property rights, including but not limited to reverse engineering, copying or translation.

Violators of the intellectual property rights of the RMOC or the organizer will be held legally accountable as requested by the owner(s) of the intellectual property.

Reading Tips

Symbol Descriptions

 Prohibition	 Important	 Hits and Tips	 Reference
---	---	---	---

Release Notes

Date	Version	Changes
2020.1.6	V1.1	<ol style="list-style-type: none">1. Update Competition Area description and drawings.2. Update competition rules.
2019.10.15	V1.0	First Release

Table of Contents

Statement.....	2
Reading Tips.....	2
Symbol Descriptions.....	2
Release Notes	2
Foreword.....	7
1. Introduction.....	8
2. Competition Area.....	9
2.1 Overview	9
2.2 Starting Zone.....	10
2.3 Buff/Debuff Zone	11
2.3.1 Buff Zone.....	12
2.3.2 Debuff Zone	12
2.4 Outpost Zone.....	13
2.5 Obstacle Zone.....	15
2.6 Protective Perimeter Wall Zone	16
2.7 Operator Area.....	17
2.8 Projectile.....	17
3. Technical Specification and Shared Information	18
3.1 General Technical Requirement	18
3.1.1 Energy Source	18
3.1.2 Wireless	18
3.1.3 Optical Equipment.....	18
3.1.4 Visual Feature	18
3.1.5 UWB Locating System.....	19
3.1.6 Robot Numbering.....	19
3.1.7 Aesthetic design.....	19
3.1.8 Launching Mechanism.....	19
3.2 Robot Technical Specification.....	20
3.3 Referee System's Shared Information	21
4. Competition Mechanism.....	22
4.1 Barrel Heat	22
4.1.1 Exceeding the Initial Firing Speed Limit	22
4.1.2 Barrel Heat Exceeds the Limit and Barrel Heat Cooling	22
4.2 Armor Attack.....	23
4.3 Referee System Going Offline	23
5. Competition Rundown	25
5.1 Pre-match inspection	25
5.2 Staging Area.....	25

5.3	5-Minute Setup Period	26
5.3.1	Official Technical Timeout	26
5.3.2	Team Technical Timeout	26
5.4	Referee System Initialization Period.....	27
5.5	Three-Minute Round	27
5.6	End of Competition.....	27
5.7	Results Confirmation.....	27
6.	Competition Rules.....	29
6.1	Rules	29
6.1.1	Rules Followed by People	29
6.1.2	Rules Followed by Robots	32
6.1.3	Interaction Rules	33
6.2	Severe Violation	33
6.3	Criteria Required to Win.....	34
6.4	Score	35
6.5	Ranking	35
7.	Technical Fault or Exception	36
7.1	Technical Fault.....	36
7.2	Exception Handling	36
8.	Appeal.....	38
8.1	Appeal Process	38
8.2	Appeal Validity	39
8.3	Appeal Material	39
8.4	Appeal Decision	40
	Appendix 1 Safety Instruction	41
	Appendix 2 Reference Drawings	43

Table Directory

Table 2-1 Projectile Parameters and Usage Schedule	17
Table 3-1 Robot Specification	20
Table 4-1 Penalties for Exceeding the Initial Firing Speed Limit.....	22
Table 4-2 HP Deduction of Armor Attack.....	23
Table 6-1 Types of Severe Fouls.....	33
Table 6-2 Points for Group Stage.....	35
Table 7-1 Malfunctions	36

Diagram Directory

Figure 2-1 Oblique-view of Infield	9
Figure 2-2 Element Number of Infield	10
Figure 2-3 Main Dimensions for Infield	10
Figure 2-4 Starting Zone	11
Figure 2-5 Single Buff/DeBuff Zone	11
Figure 2-6 Dimensions for Camera Support	13
Figure 2-7 Three-view of Camera Bracket	14
Figure 2-8 Camera Bracket	14
Figure 2-9 Dimensions for Obstacle Block	15
Figure 2-10 Number of Vision Marker	16
Figure 2-11 Dimensions for Protective Perimeter Wall Zone	17
Figure 4-1 HP Deduction Mechanism of Referee System Important Module Going Offline	24
Figure 4-2 Armor Module ID Setting	24

Foreword

Robotics is currently one of the most mainstream cutting-edge technologies in the world.

Robots are not only the key supporting equipment for advanced manufacturing, but also an important carrier for improving human lifestyle. Whether it is an industrial robot applied in a manufacturing environment or a service robot applied in a non-manufacturing environment, its R&D and industrial application are important standards for measuring a country's technological innovation and high-end manufacturing development.

Since 2015, DJI has launched the RoboMaster Robotics Competition, hoping to cultivate a group of talented engineers and scientists. In this competition, the teams need to develop a group of ground robots and aerial robots to fire projectiles on the battlefield and fight each other. The data interaction of the robots is monitored by a special referee system. The referee system converts damage inflicted by projectiles into dynamic changes in HP, and finally presents it to the audience on a game-like viewing page. The competitive mode of modern robots is constantly evolving.

In recent years, deep learning technology has also been brought up in numerous fields, reshaping the frontiers of computer vision and other areas of artificial intelligence research. In robot research, deep neural network (DNN)-based reinforcement learning enables robots to make decisions autonomously. As well-known games such as Go, Warcraft, and StarCraft are used as research platforms, the potential for the application of robotic autonomous decision-making in our daily life is unlimited.

As an emerging robotics academic platform, RoboMaster Organizing Committee launched the ICRA RoboMaster AI Challenge, which enables global enthusiasts to research deep neural network (DNN)-based robotics. Research results are expected to be applied in industries such as field rescue, driverless vehicles, and automatic logistics to benefit our lives.

1. Introduction

A standard robot platform will be provided by the competition. This standard platform is equipped with standard interfaces for features such as firing projectiles and attack detection. The teams entering the RoboMaster 2020 AI Challenge will be required to develop their own algorithms and cooperate with the equipped sensors and computing devices to enable robots to make independent decisions, move, and fire. It is not allowed to use unofficial robots. Only robots for 2019 or 2020 AI Challenge are permitted for competition.

In the competition, each team needs to prepare one or two robots to perform fully automatic firing battles with the opposing team on a 5.1m × 8.1m Competition Area. During each round, a robot reduces its opponent's HP by recognizing and firing projectiles to hit the opponent's Armor Module. At the end of each round, the team with the highest total HP Deduction by the robots wins the round.

Compared to the 2019 AI Challenge, 2020 AI Challenge has the following changes:

1. Canceled the setting of Official Projectile Supplier, and changed the supply method from preloading/loading from the Official Projectile Supplier to gaining the right to launch a certain number of projectiles by occupying the Supply Buff Zone. The Referee System will control the switch of robots' loading mechanism to control their right to fires.
2. Replaced the single Defense Bonus Zone with six Buff/Debuff Zones. Buff Zones include Restoration Zone and Projectile Supplier Zone while Debuff Zones include No Shooting Zone and No Moving Zone. Buff/Debuff Zones are refreshed regularly and distributed randomly.
3. The number and distribution places of Obstacles set inside the Battlefield are also changed, with different Vision Markers to help with locating.
4. Each corner of the Battlefield will have a Outpost Zone, and each team have two diagonal Zones. Outpost Zone can be installed with monocular camera and connect to the computer outside the Battlefield to help observing the whole area and share information to each robot of their own teams.
5. The RoboMaster UWB Locating System has been officially removed from the competition, and teams will not be allowed to use UWB tags for localization.
6. Differentiated HP deduction caused by armor attack for different Armor Modules. Reset some basic robot parameters, including HP value and barrel heat.
7. Robots cannot be placed at the Starting Zone at random angles, and new methods will be applied to ensure the effect of global localization.
8. The referee system will share some information with all robots on the Battlefield, for example, every robot's HP and number of projectiles that can be launched.

2. Competition Area

2.1 Overview



Note: The error margin of all battlefield components described here is within $\pm 5\%$. Dimensions are in millimeters.

The core Competition Area of RoboMaster 2020 AI Challenge is called the “Battlefield”. Battlefield is 8080 millimeters long by 4480 millimeters wide, consisting of Protective Perimeter Wall Zone (A), Obstacle Zone (B), Starting Zone (C), Outpost Zone (D), Obstacle Vision Markers (E), Buff/Debuff Zone (F), etc.

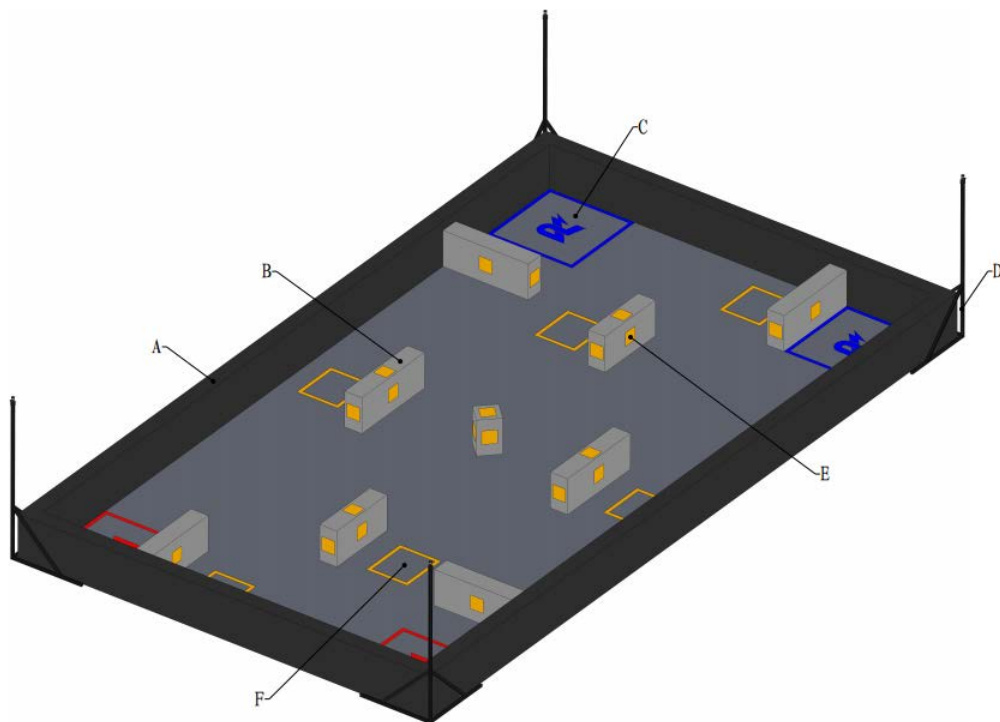

Figure 2-1 Oblique-view of Infield

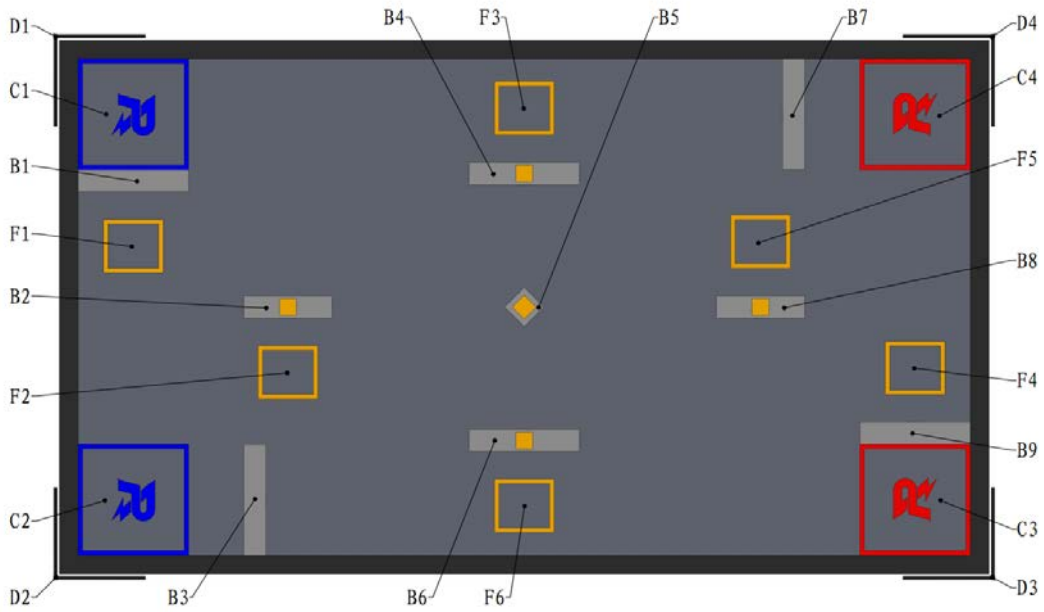

Figure 2-2 Element Number of Infield

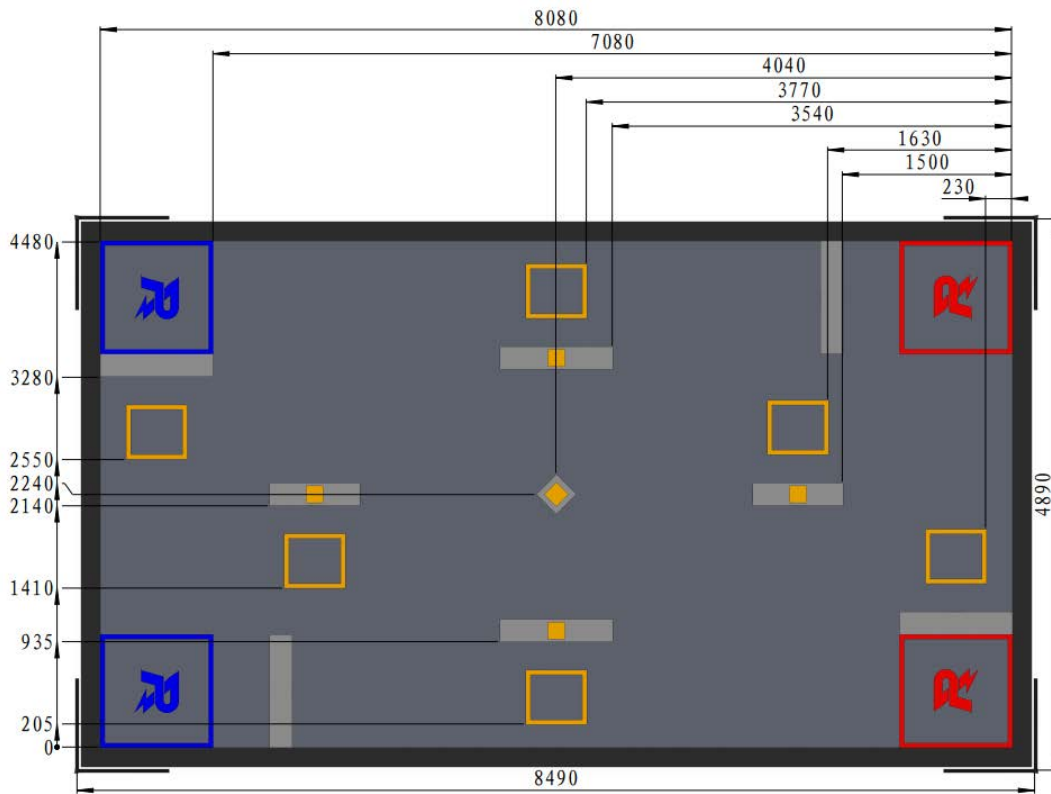

Figure 2-3 Main Dimensions for Infield

2.2 Starting Zone

The Starting Zone is where the robots are placed before the competition officially begins. The four Starting Zones from C1 to C4 are arranged in the four corners of the Competition Area. The blue team and the

red team will have two Starting Zones of exactly the same size respectively, in each of which only one robot will be allowed. When the team only has one robot, it can be placed on either of its two Starting Zones. The Starting Zone will be marked by a red or blue sticker on the flooring adhesive.

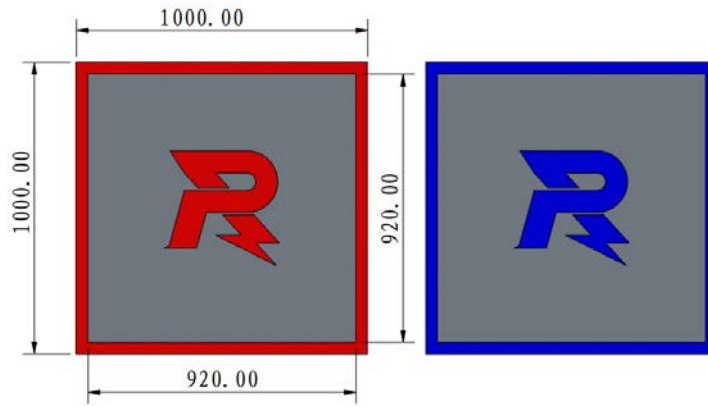

Figure 2-4 Starting Zone

2.3 Buff/Debuff Zone

Six Buff/DeBuff Zones numbered from F1 to F6 are located on site. All of them are surrounded by yellow lines and have a rectangle area side length of 540 mm * 480 mm. The three Buff/DeBuff Zones numbered F1, F2, and F3 and the three Buff/DeBuff Zones numbered F4, F5, and F6 are symmetric with each other from the center.

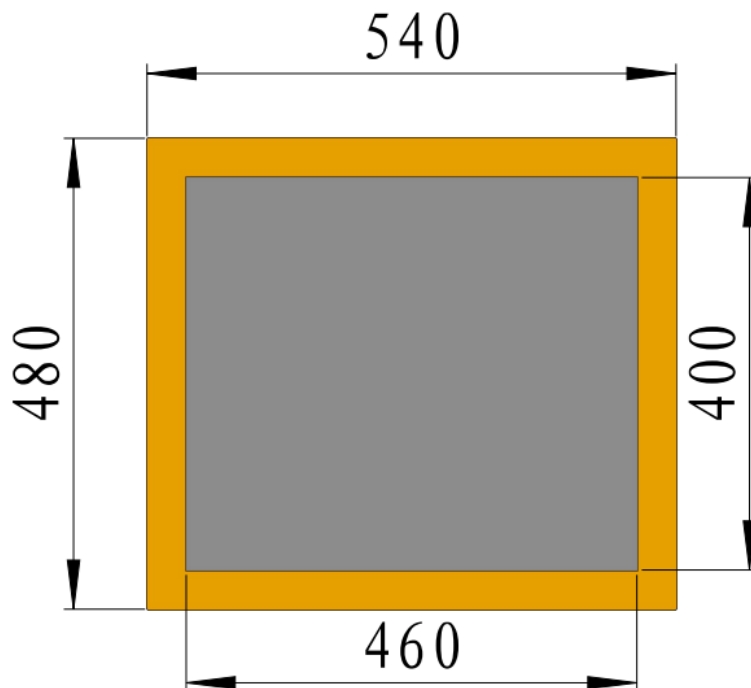

Figure 2-5 Single Buff/DeBuff Zone

At the commencement of the match, one minute after the start of the match (i.e., 2:00 countdown) and two minutes after the start of the match (i.e., countdown 1:00), the system will periodically reset the position distribution of the Buff/Debuff Zone, and share the position and status information of the current Buff/Debuff Zone with the robots which are then on the field through the referee system, and the sharing frequency is 1 Hz. The randomization rule ensures that the locations of the Buff Zones are symmetrical to the center.

For example: F1 - Red team Restoration Zone; F2 - No Shooting Zone; F3 - Blue team Projectile Supplier Zone; F4 - Blue team Restoration Zone; F5 - No Moving Zone; F6 - Red team Projectile Supplier Zone

Once a Buff/Debuff Zone is activated, the activation state will continue until next scheduled random reset, during which it cannot be activated again. If the debuff time of a certain robot is not over and the robot activates the same Debuff Zone again, it continues to be debuffed, with the debuff duration reset to 10 seconds.

For example: 55 seconds after the start of the match, No. 1 robot of the Blue Team activates the No Shooting Zone. One minute after the start of the match, the system randomly resets the Buff/Debuff Zone. At this time, this robot activates the No Shooting Zone, and the robot's no shooting debuff duration is reset to 10 seconds.

2.3.1 Buff Zone

Buff Zones include a Restoration Zone and a Projectile Supplier Zone. Both Red and Blue Teams have Buff Zones. This Zone is activated by any robot passing through. Buff only depends on the team the activated zone belongs to, and not related to the robot that active the zone.

For example: No.1 robot of the Red Team passes through and activates the Blue team Restoration Zone, both robots of the Blue Team receive the Buff of restoring 200 HP

- Restoration Zone: 200 HP
- Projectile Supplier Zone: 100 rounds of projectiles

2.3.2 Debuff Zone

Debuff Zones include a No Shooting Zone and a No Moving Zone. The Zone is activated by any robot passing through. When a robot activates any of the Debuff Zone, the robot will receive corresponding debuff.

- No Shooting Zone: Robot is unable to shoot for a duration of 10 seconds
- No Moving Zone: Robot's chassis cannot move for a duration of 10 seconds

2.4 Outpost Zone

The four rooftops of the site from G1 to G4 are the Outpost Zones. Both the red and blue sides have two diagonally facing Outpost Zones. The Outpost Zone provides a camera interface where the teams can mount a monocular camera. G1 and G3 are Outpost Zones of the Red Team, G2 and G4 are Outpost Zones of the Blue Team. The camera is mounted 2000 millimeters high.

The interface thread of camera support is 1/4" standard thread.

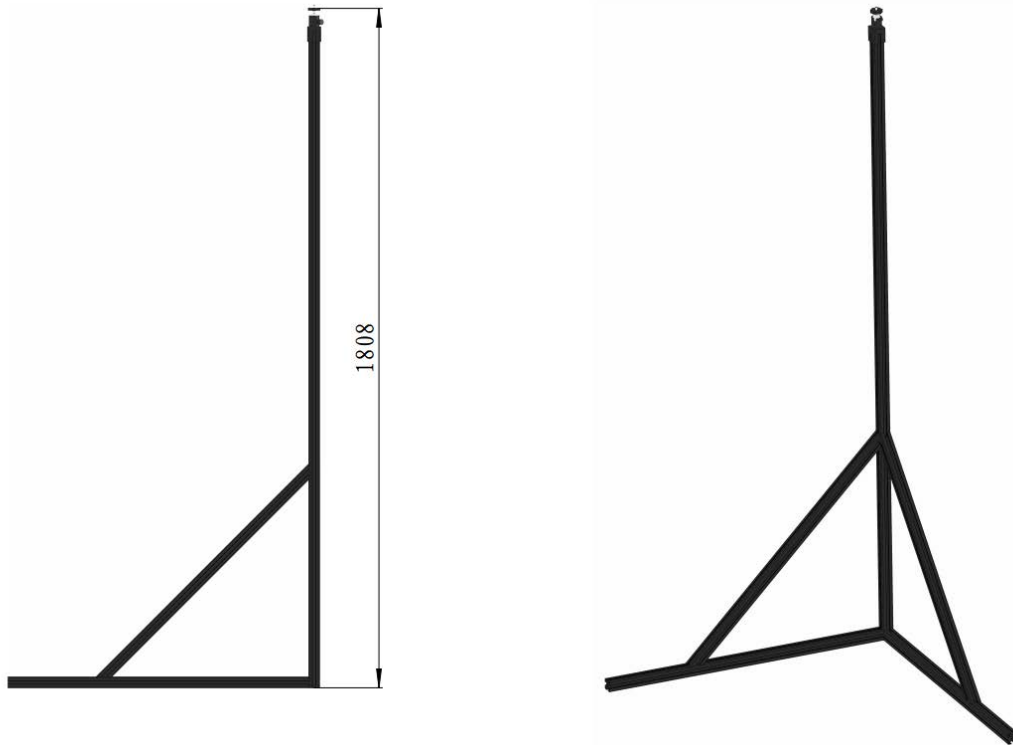
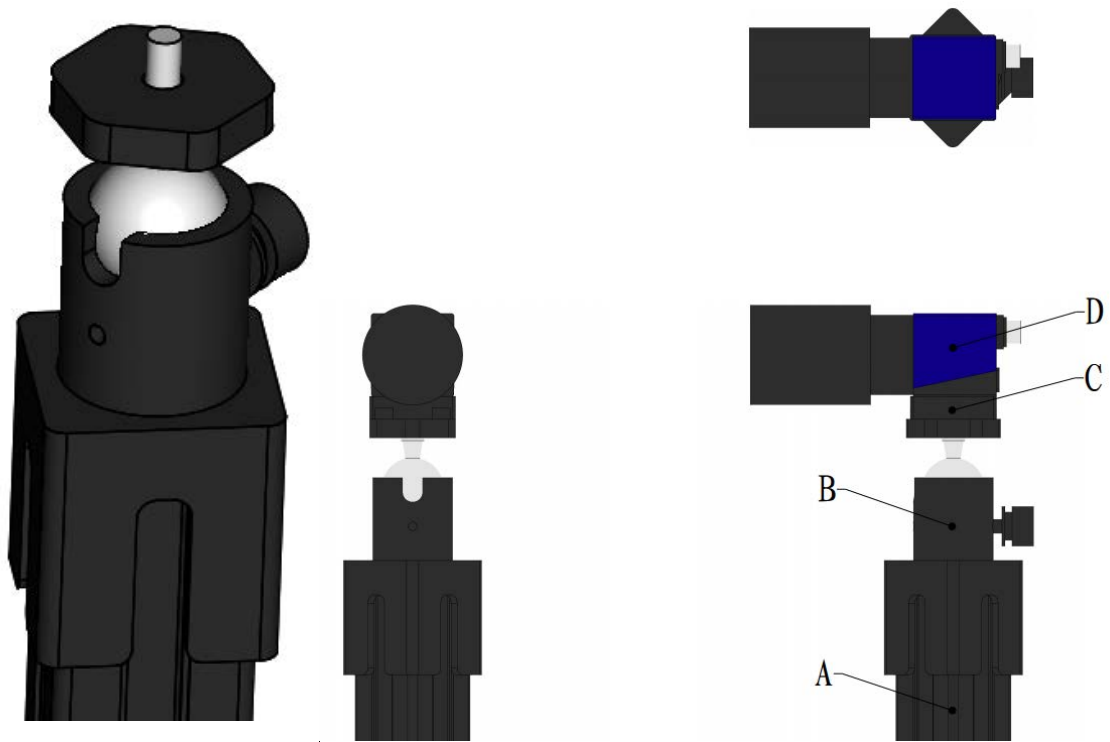

Figure 2-6 Dimensions for Camera Support



A Support B Spherical Gimbal C Adapter Board D Camera

Figure 2-7 Three-view of Camera Bracket



Figure 2-8 Camera Bracket

The RMOC provides USB extension cables and long cable extensions to the Red and Blue Teams' Operator Areas, connecting the computing platforms of the Red and Blue Teams. Other equipment such as routers, switches, camera power supply, etc. need to be provided by the participating teams themselves. Below the Outpost Zone, there will be a local-sized power supply socket for the participating teams.

2.5 Obstacle Zone

There are 9 different sizes, non-movable wooden obstacle blocks numbered B1-B9 in the Obstacle Zone. During the match, both the Red and Blue Teams' robots should make every effort to avoid collisions with obstacles. See [R38](#) for relevant penalty mechanism for runaway collisions.

The concrete size dimensions (in millimeters) of a single obstacle block are:

- Obstacle blocks numbered B1, B3, B4, B6, B7 and B9: Length * width * height = 1,000 * 200 * 400
- Obstacle blocks numbered B2 and B8: Length * width * height = 800 * 200 * 400
- Obstacle block numbered B5: Length * width * height = 250 * 250 * 400

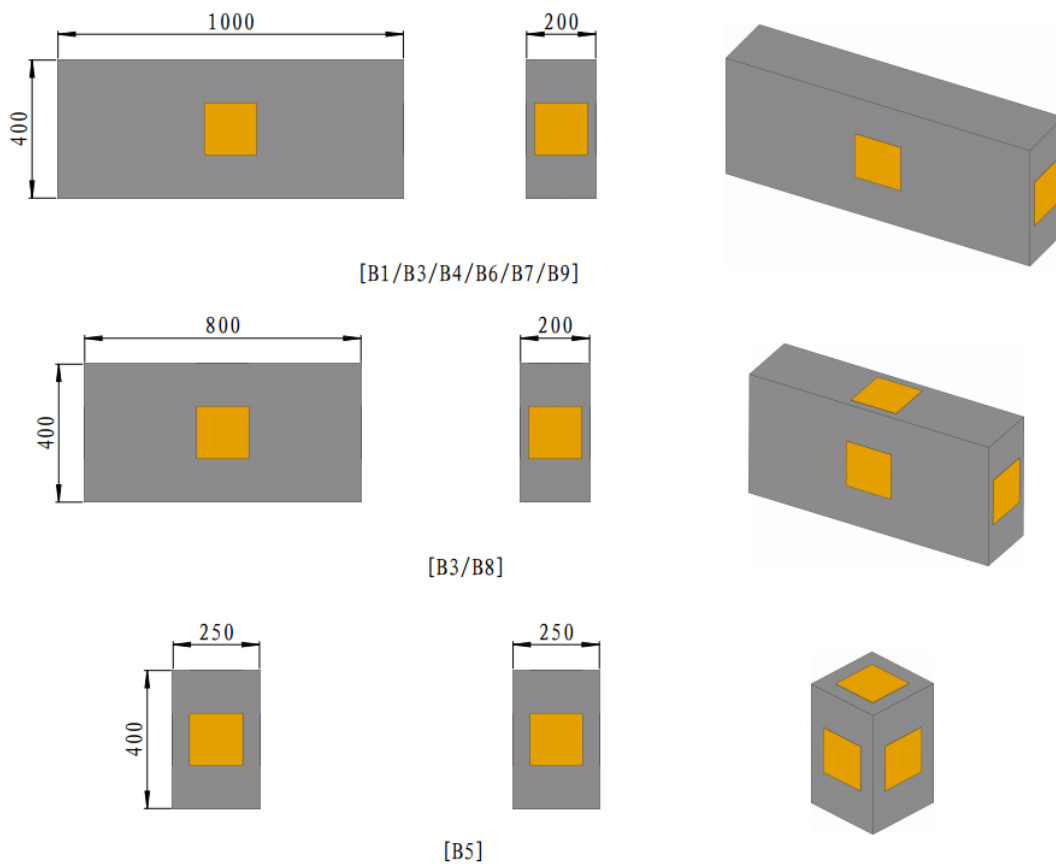

Figure 2-9 Dimensions for Obstacle Block

To facilitate the positioning and localization of the Outpost camera, the exposed surfaces around all

obstacle blocks are affixed with Vision Markers to assist robot positioning, and the upper surfaces of the obstacle blocks numbered B2, B4, B5, B6, and B8 are additionally labeled with Vision Markers. The Vision Marker is located at the geometric center of the surface of the obstacle block. It is a yellow square marker with a side length of 150 millimeters. The patterns are different and are randomly selected from the “RoboMaster 2020 AI Challenge Vision Marker Library”. Color code for vision marker is: RGB: R255 G179 B0; CMYK: C0 M30 Y100 K0; HEX: FFB300.

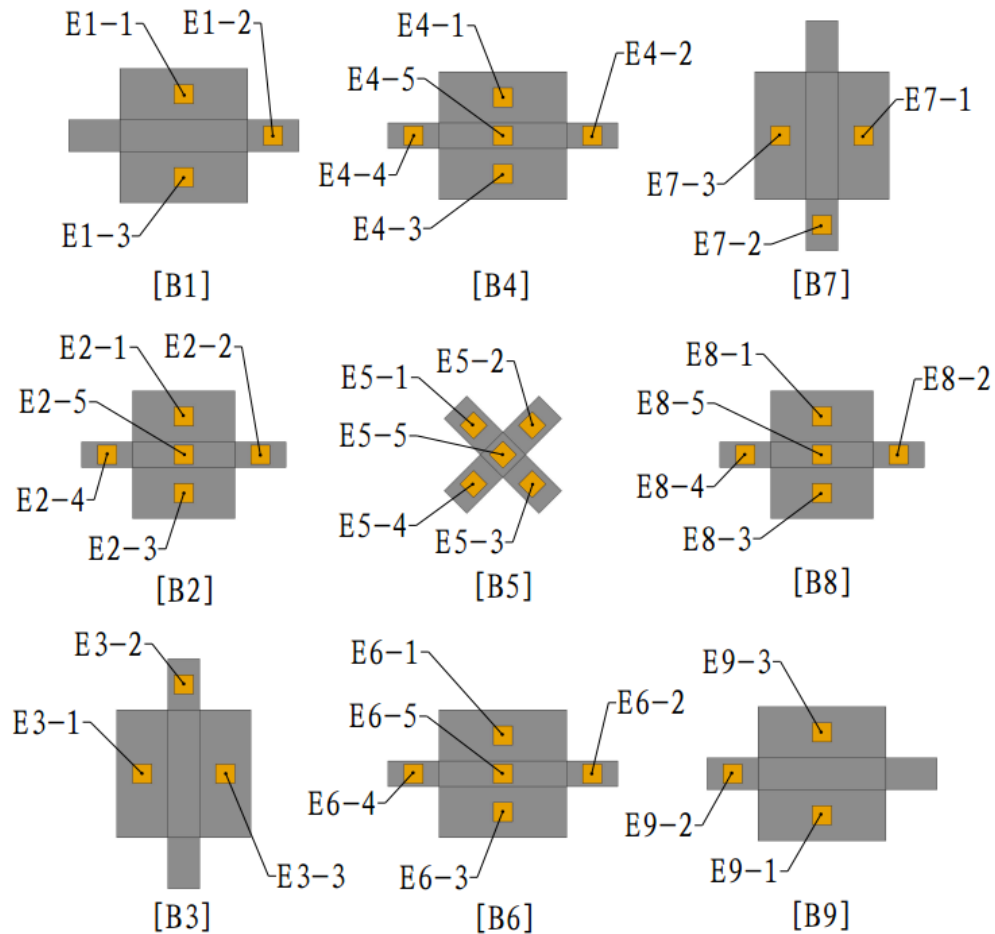

Figure 2-10 Number of Vision Marker

2.6 Protective Perimeter Wall Zone

A protective perimeter wall is set up around the Competition Area. Robots from both the red and blue teams should avoid colliding with the wall. See [R38](#) for relevant penalty mechanism for runaway collisions.



Figure 2-11 Dimensions for Protective Perimeter Wall Zone

2.7 Operator Area

The Operator Areas for both teams are located in the fixed areas on the same side outside the Competition Area.

2.8 Projectile

Projectile is the only acceptable component for robots to attack. Robots must use projectiles to hit the Armor Modules of the enemy robots, causing damage to their HP and defeat them. Below shows projectile parameters and usage schedule:

Table 2-1 Projectile Parameters and Usage Schedule

Type	Version	Appearance	Color	Size	Weight	Shore Hardness	Material
17mm projectile	2019	Round	Yellow-green	16.8mm (±0.2mm)	3.2g (±0.1g)	90A	Plastic (TPU)

3. Technical Specification and Shared Information

R# Rules clearly indicate the rules to be followed by the participating teams, participants and participating robots.

3.1 General Technical Requirement

3.1.1 Energy Source



During the competition, if there is a safety hazard with a battery, a Technical Referee will put the hazardous battery into an explosion-proof tank, and will not return it to the participating team until the safety hazard is eliminated.

R1 The energy source used by robots is limited to electrical power supply.

R2 Only lithium batteries (TB47D, TB48D) with power management and short circuit protection functions produced by SZ DJI Technology Co., Ltd. can be used.

3.1.2 Wireless

R3 The remote controller must be products produced by SZ DJI Technology Co., Ltd..

3.1.3 Optical Equipment

R4 It is forbidden to install any laser or device that emits visible light on robots.

3.1.4 Visual Feature

The armor module of the referee system is designed with clear lighting effects for the development of automatic identification and sighting algorithms. The environment of and around the Competition Area is relatively complicated. The computer vision algorithm should adapt to the changes of the lighting of the venue and other possible interferences around the venue. The RMOC cannot guarantee that the computer vision features of the battlefield will not cause visual interference.

When designing the robot's visual feature, teams should follow specifications as shown below:

R5 Robotic sensors (such as LiDARs, cameras, ultrasonic sensors, etc.) should not be installed to obstruct the Armor Module.

R6 Do not project light onto an Armor Module and do not mount any structure or device that interferes with Computer Vision feature recognition of the Armor Module by reflecting or refracting light on both sides of the Armor Module on the robot.

3.1.5 UWB Locating System

R7 UWB Locating System is no longer set up in the Competition Area, and teams are not be allowed to use UWB locating devices.

3.1.6 Robot Numbering

During the pre-match inspection and the match, the RMOC staff will paste number armor stickers on robots that are to play. For number stickers, please refer to [Appendix 2 Reference Drawings](#).

When applying armor stickers on robots, teams should follow specifications as shown below:

R8 Stickers must be applied properly with no visible air pockets and one Armor Module must be attached with one armor sticker.

R9 Except for the exclusive armor stickers provided by the RMOC, no other stickers that resemble the exclusive armor stickers may be pasted on a robot's Armor Module or its other external structure.

3.1.7 Aesthetic design

R10 Teams can appropriately increase the amount of paint on the robot, which does not interfere with computer vision recognition and fairness of the competition.

3.1.8 Launching Mechanism



Launching Mechanism: A mechanism capable of launching a projectile from a robot on a fixed trajectory to inflict damage on another robot (judge according to the mechanical structure, regardless of the power on situation of the mechanism).

R11 Launching Mechanism is not allowed to be modified.

3.2 Robot Technical Specification

Table 3-1 Robot Specification

Item	Limit	Notes
Initial HP	2000	-
Operating Mode	Fully Automatic	-
Maximum Total Power Supply Capacity (Wh)	200	-
Maximum Power Supply Voltage (v)	30	-
Maximum Chassis Power Consumption (W)	No limit	-
Launching Mechanism	A 17mm Launching Mechanism	The installation of laser sight is prohibited
Projectile Supply	Activate the Projectile Supplier Zone	-
Initial Projectile Quantity (round)	Fill the Projectile Container until it is full	After game begins, only Robot#1 gains the right to launch 50 projectiles initially
Initial Firing Speed Limit for Projectiles (m/s)	25	-
Barrel Heat Limit	240	Refer to 4.1 Barrel Heat
Maximum Weight (kg)	25	Include the battery weight, but not the weight of the Referee System

Item	Limit	Notes
Maximum Initial Size (mm)	600*600*500	Its orthographic projection on the ground should not exceed a 600*600 square
RoboMaster Referee System	Four small Armor Modules, Speed Monitor Module (17 mm projectile), RFID Interaction Module, Main Controller Module, Power Management Module, Light Indicator Module	-

3.3 Referee System's Shared Information



The specific communication specifications and reading are subject to the latest announcement by the RMOC soon.

Some of the match information shared by the referee system with the robot on site is as follows:

- Robot status, HP value, and number of projectiles that can be launched
- Match round and time
- Buff/Debuff Zone location distribution, activation status, etc.

Information obtained for a single robot is as follows:

- Launching Mechanism's current launch speed, launch frequency and barrel heat
- HP deduction (including the reason for the deduction, the number of the Armor Module being attacked, etc.)
- Power status of each Module (Launching Mechanism, gimbal, chassis, and onboard computer)
- Number of projectiles that have been launched
- Current robot number

4. Competition Mechanism

Robot's HP will be deducted if such situation occurs: the barrel heat of the Launching Mechanism exceeds the limit; the initial speed exceeds the limit; the Armor Module is attacked or hit; important modules go offline; and/or violation of rules. When the referee system server calculates the HP, it rounds off the decimal point of the deducted HP.

4.1 Barrel Heat

The current initial speed is V (m/s), and the current barrel heat is Q .

4.1.1 Exceeding the Initial Firing Speed Limit

If $V > 25$ m/s, when the referee system detects a projectile, the robot's HP is deducted by a value of L .

Table 4-1 Penalties for Exceeding the Initial Firing Speed Limit

V	L
$25 < V < 30$	200
$30 \leq V < 35$	1000
$V \geq 35$	2000

4.1.2 Barrel Heat Exceeds the Limit and Barrel Heat Cooling

When a match starts, the initial barrel heat of each robot is 0. Each time a projectile with a velocity of V (m/s) is launched, the robot's barrel heat is increased by the value of V .

During a match, the robot's barrel heat upper limit is 240 and the cooling value per second is 120.

If the robot's HP is less than 400, then the cooling value per second is 240.

The barrel heat is settled at a frequency of 10 Hz (the cooling value of heat per period = cooling value per second / cooling settlement frequency).

- If $360 > Q > 240$, a value of $(Q - 240) * 4$ of HP is deducted per period, and then the HP is settled and cooled.
- If $Q \geq 360$, a value of $(Q - 360) * 40$ of HP is immediately deducted, and $Q = 360$ after deduction.

4.2 Armor Attack



In an actual match, the normal speed of a projectile that touches the Armor Module attack surface is different from its initial firing speed due to the projectile's speed decay and its incident angle not being normal to the Armor Module attack surface. Damage detection is based on the normal component of the projectile's speed upon contact with the Armor Module attack surface.

An Armor Module detects projectile attacks using the pressure sensor combined with the Armor's vibration frequency.

The smallest detection interval for an Armor Module is 50 ms.

The projectile needs to come into contact with the impact surface of the Armor Module at a speed of 12 m/s or higher in order to be successfully detected.

A robot will also experience damage when its Armor Module is struck. However, a robot cannot cause HP damage to the other side's robots through striking (including collision with the robots or launching objects).

Below are HP deductions in situations of no buff:

Table 4-2 HP Deduction of Armor Attack

Attack Type	HP Deduction
Projectile	<ul style="list-style-type: none">● Forward Armor Module: 20● Left and right Armor Modules: 40● Rear Armor Modules: 60
Collision	10

4.3 Referee System Going Offline

The stability of connection between each module and server of the referee system should be maintained during the matches. The referee system server detects the connectivity of each module at a frequency of 2 Hz. If important Referee System module such as Speed Monitor Module or Armor Module goes offline due to problems caused by the design and structure of the robot, the corresponding amount of robot HP will be deducted.

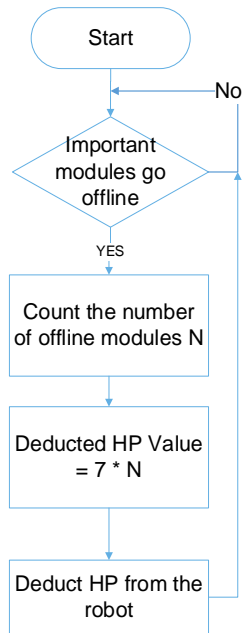
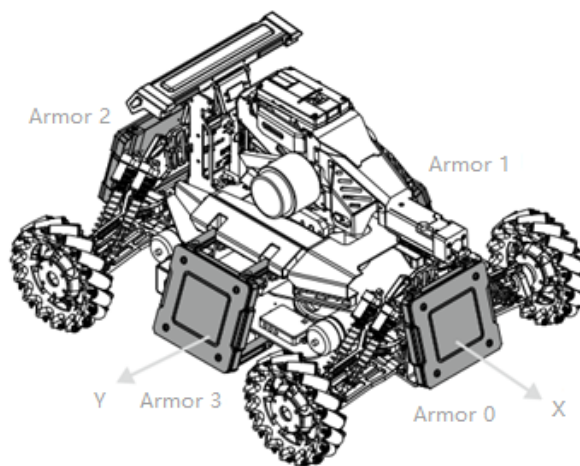

Figure 4-1 HP Deduction Mechanism of Referee System Important Module Going Offline

Armor Module ID Setting

The Armor Module must be configured with the correct ID number before the pre-match inspection. The specific requirements are as follows:

Establish the Robot Coordinate System according to the Armor Module installation requirements. In other words, after entering the armor ID setting mode, tap the Positive X axis, the Negative Y axis, the Negative X axis, and the Positive Y axis in turn to complete ID settings as shown below. Set Armor Module ID



[1] Armor #0 [2] Armor #1 [3] Armor #2 [4] Armor #3

Figure 4-2 Armor Module ID Setting

5. Competition Rundown

5.1 Pre-match inspection

To ensure that robots meet the required specifications, each team must undergo a Pre-Match Inspection in the Inspection Area 40 minutes before the start of each match.

A maximum of six team members for each team can enter the Inspection Area. A robot can be brought to the Inspection Area by a maximum of two team members. One team member is responsible for assisting the staff with the Pre-Match Inspection. Other team members are prohibited from entering the Inspection Area without permission of the Head Inspector Team members are prohibited from entering the Inspection Area without permission before their robots enter the Inspection Area.

During the Pre-Match Inspection, inspectors will place a Pass Card on robots that pass the inspection. Only robots with a Pass Card and the Card is fully marked can enter the Staging Area and Competition Area. Teams need to modify their robots that fail the Inspection in the Preparation Area until the inspection requirements are met.

When the inspection is complete, the team Captain must sign the inspection form to confirm that they agree with the inspection results. After the team Captain signs for confirmation, no objection may be raised to the results of the inspection.

During each match, each team can carry at most two standby robots. When a standby Standard is required to play a match, Pit Crew must promptly get the corresponding armor sticker from the Technical Referee and attach it in accordance with Robot Numbering. Only then can the standby Standard play the match. Armor sticker applying should follow requirements stated in [3.1.6 Robot Numbering](#).

Standby robots are not allowed to replace after passing the Pre-Match Inspection.

5.2 Staging Area

Staff at the Staging Area will check the status of the participating robots and the information of participants.

If any team needs to repair its robots after entering the Staging Area, it must obtain the permission of the staff at the Staging Area. Only when staff at the Staging Area has removed the Pass Card on the robot can a robot leave the Staging Area for repair. When repair is finished, the robot needs to be brought back to the Inspection Area for another Pre-Match Inspection before re-entering the Staging Area. If a delay results in the failure for the robot to enter the stage, the team will bear its own consequences.

After leaving the Staging Area, the participating teams will enter the waiting area of the Competition Area to place their robots. When the previous match has ended and with the permission of the referee, the

next pair of participating teams will wait at the entrance of the Battlefield with their robots for further instructions. After the referee has confirmed that both teams are ready, he or she will open the door and lead the team members into the Competition Area. The countdown for the 5-minute Setup Period will begin when the door opens.

5.3 5-Minute Setup Period

During the 5-minute Setup Period, Pit Crew can enter the Battlefield to set up the robots and cameras attached to Sentry and start the related program. Pit Crew can use remote controllers, laptops or any other electronic device in the Battlefield or Operator Area to control the robot.

When the Setup Period is left with 30 seconds, all robots in the Battlefield must be powered up, and the staff in the Battlefield should leave the Competition Area in an orderly manner. Pit Crew must place remote controllers and laptops used for debugging in the designated Operator Area outside the Battlefield.

5.3.1 Official Technical Timeout

During the 5-minute Setup Period, if modules related to a Referee System experience any faults (see [Table 7-1](#)), the Head Referee can announce an Official Technical Timeout and pause the countdown.

During an Official Technical Timeout, the team members can only assist with the Technical Referee to eliminate the malfunctions of the relevant referee system modules and cannot repair other malfunctions. They must leave the Battlefield when the Referee System has been repaired.

5.3.2 Team Technical Timeout

If the mechanical structure or software system of the robot fails, the team can apply for the "Team Technical Timeout" to the Head Referee before entering the 15-second countdown in the five-minute setup period, and explain the reason for the application. Team Technical Timeout once requested and conveyed to the Head Referee, this Timeout cannot be canceled or revised.

The Head Referee will inform both teams of the Team Technical Timeout regardless of which team requests. Pit Crew can use the Technical Timeout to enter the Battlefield to repair their robots. Team members can only adjust their own robots in the Starting Zone.

When a Team Technical Timeout is initiated and confirmed by the Head Referee, the team uses up one of its allotted Timeouts regardless of the premature end of the Timeout. At this point, the Referee will continue the Technical Timeout countdown or end prematurely when he confirms that both teams are ready.

To ensure that subsequent matches begin on time, only one Team Technical Timeout is allowed per Setup Period. Technical Timeout usage is recorded in the Match Results Confirmation Form. The type of Technical Timeout is determined by the Head Referee based on the request of the team. The team cannot dispute the type of Technical Timeout and the Technical Timeout process may not be used as a basis for appeals after the match.

Each team will be allowed to initiate two Team Technical Timeouts, which will last three minutes each. Once all Team Technical Timeout requests are used, the team can no longer request.

5.4 Referee System Initialization Period

After the 5-minute Setup Period, the match enters a 20-second Referee System Initialization Period. During the Initialization Period, the competition server will automatically detect the Referee System module status of the robot, the status of Battlefield Components and restore the HP of all robots, ensuring their HP are full when the match officially begins.

If the initialization does not meet the requirements of the start of the round, such as an offline robot or Battlefield Component, the countdown will be suspended. A Pit Crew member of each team is allowed to enter the Battlefield to check on the fault.

When the Referee System Initialization Period is left with 5 seconds, the RMOC staff will notify team members. When the countdown finishes, the match starts immediately.

5.5 Three-Minute Round

During the Three-Minute Round Period, robots from both teams will compete on the Battlefield of the stadium.

5.6 End of Competition

A round ends either when time has elapsed or one team has fulfilled the conditions for winning. When a round ends, the match immediately enters the 5-Minute Setup Period for the next round. The match is over when the winner has been determined or all rounds are ended.

5.7 Results Confirmation

During a match, the referee will record on the Match Results Confirmation Form the penalties issued for each round and the HP Deduction of both sides at the end of the rounds, the Remaining HP of each Base, Outpost and Sentry, the winning teams, the use of Technical Timeout opportunities by teams, and other

relevant details. After the end of each match, team Captains need to be at the Referee Area to confirm the results.

Within three minutes after a match ends, Captains of both teams must confirm the match results by signing at the Referee Area. If a team Captain is not at the Referee Area within three minutes to sign and confirm the results and has not requested an appeal, it is deemed that the team agrees with the match results.

The referee will not entertain any request for appeals on match results between rounds of an individual match.

Once a team Captain has signed and confirmed the results, no further appeals can be made.

6. Competition Rules



Any penalty issued before the start of a competition will be executed after the competition officially starts. Penalty of violation stated in this chapter will be determined by the Head Referee according to the actual situation.

To ensure the fairness of the competition and uphold discipline in the competition, participating teams and robots are required to adhere strictly to the Competition Rules. Referee will issue the appropriate penalty against any violation of rules.

Serious violations and appeals in the competition will be publicized.

6.1 Rules

This section introduces the rules of the game and defines the corresponding measures taken by the referee after the violation.

6.1.1 Rules Followed by People

6.1.1.1 Participating Team/Participant

R12 Teams should follow specifications as shown below:

- R12.1 Multiple teams of the same school are eligible to participate in the competition.
- R12.2 The team name must be in the format of “school name + team custom name + team”.
 - A. The first part is the school name of the team. Abbreviations are allowed.
 - B. The second part is the custom name of the team. The total length of the custom team name should not exceed 16 characters (one Chinese character counts as two characters; one English letter counts as one character). The team name should showcase the team's proactive attitude and their pursuit for excellency.
 - C. The names of multiple teams in the same school need to be different.
- R12.3 Any participant can only participate in one team during the during the RM2020 AI Challenge.

Penalties:

- If any of Item R12.1-R12.2 has not been met, the RMOC will reject the application. The participating team can reapply until it meets the requirements.

- If Item R12.3 has not been met, a Verbal Warning will be given to the team. If the Verbal Warning is ineffective, according to the seriousness of the situation, the highest penalty that can be given to the offending party is disqualification.

R13 Each team must arrive at the Inspection Area for the pre-match inspection at least 40 minutes before the match begins.

Penalties: Forfeiture of the current match.

R14 The team is not allowed to launch projectiles in the Staging Area. If testing is required, it must be reported to the staff in advance and tested with a storage bag.

Penalties: Verbal Warning. If the Verbal Warning is ineffective, the offending party shall be disqualified.

R15 The participating teams can set up their own wireless network within the five-minute setup period, but the network should be set with a specific frequency band of 2.4 or 5.8 GHz, and the upper limit of the occupied bandwidth is 40 MHz.



Due to a large audience and a large number of devices used for live broadcast during the competition, there will be many unknown Wi-Fi signal sources. The RMOC does not guarantee the stability of Wi-Fi networks built by participating teams.

Penalties: The team will be issued a forfeiture for the round.

R16 Wireless network that setup by teams can only be used for the communication between its own robots and the Outpost host, or be used for debugging its own robots and the Outpost program during the five-minute setup period. The network should not intervene with the running of related referee system devices and the enemy robots.

Penalties: The offending party shall be disqualified.

R17 The computing device for processing the visual information of the Outpost or other debugging devices should be placed on the Operator Area. The team members are not allowed to operate related devices after the Referee System Initialization Period starts.

Penalties: The team will be issued a forfeiture for the round.

R18 Pit Crew must ensure that their robots work safely and will not injure any person in the Competition Area.

Penalties: The offending party shall bear the corresponding responsibility.

R19 Team member should not leave the Staging Area without the referees' permission.

Penalties: The offender will be prevented from accessing the Competition Area.

R20 The participating team is not allowed to destroy the equipment in the Operator Area

Penalties: The referee will issue a verbal warning and ask the offending party to pay compensation according to the price.

R21 Members from both teams must power off all their robots and remove them from the Competition Area when the match is over. Teams are required to empty all projectiles from the robots in the designated area and then return to the Preparation Area.

Penalties: The robot will be detained in the Projectile Unloading Area.

6.1.1.2 Pit Crew



Pit Crew: Team member and Supervisor or Advisor who have registered for this Season and have been entered into the registration system, can walk into the Preparation Area and Competition Area.

R22 During each match, up to six Pit Crew members per team can enter the Staging Area and Competition Area.

Penalties: Verbal Warning. If the Verbal Warning is ineffective, the team shall be issued a Forfeiture of the match.

R23 The identity of Pit Crew members should meet the requirements.

Penalties: Verbal Warning. If the Verbal Warning is ineffective, the team shall be issued a Forfeiture of the match.

R24 During five-minute setup period, Pit Crew can only test the robot within one meter of their own Starting Zone.

Penalties: Verbal Warning. If a team member repeatedly fails to heed the warning, the robot that fails to comply with the rules will be banned from this round of the match.

R25 During five-minute setup period, the Pit Crew must not pick up the projectiles scattered on the floor of the Competition Area.

Penalties: Verbal Warning. If the Verbal Warning is ineffective, the offending party shall be issued a Forfeiture of the round.

R26 During five-minute setup period, the Pit Crew must not pick up the projectiles scattered on the floor of the competition area and directly supply to their own robots.

Penalties: The robot is not allowed to play.

R27 During the last 30 seconds of the five-minute setup period or the last 20 seconds of the Team Technical Timeout, Pit Crew should leave the Battlefield as soon as possible.

Penalties: Verbal Warning.

R28 At the end of the five-minute setup period, Pit Crew from both teams must return to their designated area outside the Battlefield.

Penalties: The offender will be ejected from the Operator Area, and the team is forbidden from having a substitute member enter the Operator Area for all of the remaining rounds of the current match. If the Verbal Warning is ineffective, the offending party shall be issued a Forfeiture of the round.

R29 When referee system initialization period starts, each team can send a maximum of two team members to watch the remote controls, computers and other electronic devices in the Operator Area, and observe the state of the robots. Pit Crew members are not allowed to operate the robots on the Battlefield in any form unless under special circumstances or with the consent of the referee. Other Pit Crew members must stay in the pit area outside the Battlefield.

Penalties: Verbal Warning. If the Verbal Warning is ineffective, the offender will be ejected from the Operator Area, and the team is forbidden from having a substitute member enter the Operator Area for all of the remaining rounds of the current match. If the warning(s) is ineffective, the offending party shall be issued a Forfeiture of the round.

R30 Each Robot can use at most one remote controller and one receiver. After five-minute setup period, it is not permitted to use remote controller.

Penalties: The offending party shall be disqualified.

6.1.2 Rules Followed by Robots



For example, If there are serious damages to a robot in the match and there are serious safety hazards such as short circuit, the robot must be immediately powered off and brought to the designated area to avoid safety risks in subsequent matches. The actual situation shall be determined by the Chief Referee.

R31 Robots entering a match must pass the Pre-Match Inspection.

Penalties: Forfeiture of the current round.

R32 At least one robot must enter the stage.

Penalties: Forfeiture of the current match.

R33 Robots must be attached with their corresponding armor stickers that meet the specifications.

Penalties: The offending robot is not allowed to enter the stage.

R34 Before 5-minute Setup Period, the robot must not launch a projectile or initiate any physical injury to the staff.

Penalties: Forfeiture of the current round and the offending party must bear the relevant responsibility.

6.1.3 Interaction Rules

6.1.3.1 Interaction between Robots

R35 R52 Except for slowly pushing away a destroyed robot that is obstructing the path, a robot must not use any of its structures to collide with the enemy's robots.

Penalties: According to the intention or the degree of collision, eject the offending robot.

R36 A robot must not stick itself to any enemy robot through active interference, blocking or collision.

Penalties: According to the situation of getting stuck together or the influence imposed to the competition, the offending party will receive a forfeiture for the round.

6.1.3.2 Between Robot and Battlefield Component

R37 During any match in RM2020, participating robots can only use projectiles supplied by the RMOC.

Penalties: Verbal Warning. If the Verbal Warning is ineffective, according to the seriousness of the situation, the highest penalty that can be given to the offending party is disqualification.

R38 If one robot voluntarily makes fast and repeated frontal collisions with obstacles, or collides with obstacles which forces them a long distance away or keeps moving the obstacles, the referee will deem this behavior as collision due to loss of control and eject the robot.

Penalties: Deemed as runaway collision and eject the offending robot.

6.2 Severe Violation

The following actions are considered a severe violation of rules. Any serious violation by an individual or a team will lead to a maximum penalty of disqualification from the competition. The team will be prohibited from participating in the current competition season and receiving any awards. The match results of this team will still be documented as reference for the other teams' advancement in the competition.

Table 6-1 Types of Severe Fouls

Item	Type
1	Violate rules mentioned in this document but refuse to accept penalties, for example, Pit Crew member intervenes with the referee, etc.
2	Refuse to immediately leave the Competition Area after the match ends, affecting the match process

Item	Type
3	Install explosives or other prohibited materials on robots
4	Team members use robots to crash into or attack people, creating safety risks
5	Team members purposely damage the opponent's robots, Battlefield Components and related equipment
6	Team members engage in a physical confrontation with the referee, their opponents, or the audience
7	Team members do not cooperate when the RMOC is hearing an appeal
8	Other severe actions that go against the guidelines and spirits of the competition, and the penalties will be determined by the Head Referee and Chief Referee according to the actual violations
9	During the competition, violation of local laws and regulations inside the Competition Area or Audience Area. In addition to being disqualified from the competition at the highest extend, the RMOC will fully cooperate with the relevant authorities to pursue appropriate legal action against the offender
10	Change or damage the Referee System, or affect any measuring function of the Referee System through technical tricks
11	Other behavior that violates the game spirit or is determined to be cheating by the Chief Referee

6.3 Criteria Required to Win

The official matches of RM2020 AI Challenge consist of the Group Stage and the Knockout Stage. The competition system for the Group Stage is BO1 and that for the Knockout Stages is BO3.

The following are the criteria for winning in a single round:

1. The match ends immediately when all the robots of a team are destroyed, and the team with surviving robot(s) wins.
2. When the entire time of a round is up, if robots of both teams have survived, the team with the higher damage output wins.

If neither team fulfills these criteria, the round is considered a draw. A draw in the quarterfinals leads to an immediate tie-breaker round until a team wins.

6.4 Score

Below shows the points for Group Stage:

Table 6-2 Points for Group Stage

Competition System	Competition result	Points	Notes
BO1	1:0	1:0	(draw for one round): The team winning one round gains 1 point
	0:0	0:0	(draw for two rounds): Each team gains 0 point

6.5 Ranking

Group Stage

The ranking of the Group Stage is determined by the total score of each game; the knock-out stage is determined by the number of wins. The following criteria are used to determine rankings in a descending order of priority:

1. The team with the higher number of total match points ranks higher.
2. If the total Net Base HP are the same, the team with the higher total HP Deduction ranks higher.
1. If two or more teams still tie for the same place according to these criteria, the RMOC will arrange a playoff match on a round-robin basis.



HP deduction: For each round of competition, the difference between the total initial HP and the total remaining HP by the end the round

- “Ejection of robots” means deducting the total HP of the robot and such penalty will be counted into the deduction inflicted by the opponents.
- HP deducted from the Initial Firing Speed exceeds the limit, Barrel Heat exceeds the limit and the Referee System goes offline are not counted as HP Deduction.

Knockout Stage

A team wins the Knockout Stage if it has won the most number of rounds: BO3 requires the winning of two rounds.

7. Technical Fault or Exception

7.1 Technical Fault

The malfunctions that caused the official technical timeout during the five-minute setup period are as follows:

Table 7-1 Malfunctions

Rule	Description
1	The official devices are malfunctioning.
2	During the five-minute setup period of the first round, there is a malfunction with the referee system modules at the robot end. For example, the robot cannot be connected to the server of the referee system.
3	Key Battlefield Components are found with structural damages or malfunctions (Outpost structure has damages or moves obviously, Obstacle Block moves, etc.)
4	Other situations where the head referee deems it necessary to call an official technical timeout.

If Rule 2 occurs during the Setup Period of the second round or later rounds or within the three-minute match round, the damage will be considered incidental and an Official Technical Timeout will not be permitted. In these situations, it is too hard to determine whether the malfunctions were caused by the referee system modules, a failure in the robot's mechanical or electrical system design, or operational mistakes made in previous matches. However, Technical Referee will provide backup referee system modules, and the team can request a Team Technical Timeout to repair their robots. Technical Referee will provide backup referee system modules. The team can request a Competing Team's Technical Timeout to repair their robots.

7.2 Exception Handling

If an abnormal situation or exception occurs during the game, the processing method is as follows:

- When severe safety risks and exception of robots arise on the Battlefield (battery explosion, Aerial flying towards the Audience Area due to broken Aerial Safety Rope, stadium power outage, explosion of a compressed gas cylinder, or interpersonal conflict), the Head Referee will notify both teams through the Operator Room Referees after discovering and confirming the emergency, and kill all robots through the Referee System. The result of the round will be invalid. When safety risks or exception is eliminated, the round will restart.

- If there is a problem affecting the fairness of the competition between two parties during the competition, the referee will judge the treatment according to the actual situation.
- If the general Battlefield Components are damaged during a match (damage to the ground rubber, ground lighting, or Base lighting), the match will proceed normally. If the key battlefield components are structurally damaged or functionally abnormal (for example, the RFID in the defense bonus zone has shifted or is unable to be activated, or an obstacle block is so poorly adhesive to the floor that a slight push easily shifts it), the head referee will inform both teams and kill all the robots through the referee system after he/she discovers and confirms the situation. The field technicians will enter the Battlefield to repair, and once the Components function normally, there will be a replay.
- If some Battlefield Components have logistic problems or structure failures that are not caused by participants in the process of the match (e.g., hit Power Rune but HP gain is not triggered, Base cannot normally open shield), the Head Referee will manually solve the problem through the Referee System. If the problem cannot be solved manually is confirmed cannot be eliminated, the Head Referee will announce to the Pit Crew on both teams that the Referee System will kill all robots. The round ends immediately, the result will be invalid. When problems are solved, there will be a replay.



This process may cause delays, and the RMOC will not be held responsible for the impact of these delays.

- During a match, if there is structural damage or malfunction of key Battlefield Components that affects the fairness of the match and the Head Referee did not confirm and end the game in time, leading to the situation that a game that should have ended continues to proceed and has victory, the result of the round is deemed invalid once confirmed by the Chief Referee, and there will be one rematch.
- If there are severe fouls, the original result will be deemed void after this situation is confirmed by the chief referee or the appeal results. The offending team will be ruled with forfeiture or disqualified.

8. Appeal

Every team has the right to one appeal during the (Chinese) regional competition. However, appeals cannot be accumulated across competitions. If an appeal is successful, the appeal right reserves; otherwise, one appeal right is consumed. When all rights are exhausted, the RMOC will not accept any appeal from the team. When processing an appeal, an Arbitration Commission, which is made up of Chief Referee and heads of the RMOC, will be formed. The Arbitration Commission makes the final decision on all appeals.

8.1 Appeal Process

Teams that filing an appeal need to follow procedures as shown below:

1. Within three minutes after the match ends, the Captain submits an appeal to the Chief Referee in the Referee Area and signs an Appeal Form. If the reason for the appeal is related to the robots of any side to the competition, it is necessary for the appellant to propose that the relevant robots be isolated and tested, which will be implemented when confirmed by the arbitration commission. The signing of the appellant represents the confirmation of the initiation of the appeal process and the appeal form may not be modified after signing. After three minutes of the match, any appeal will be deemed invalid. No appeal can be initiated before or during the match.
2. Captains of both sides will be brought by the event staff to the Arbitration Room. The Arbitration Commission checks whether the appeal can be processed.
3. If either side needs to collect evidence or defense materials for a period of one hour, the materials will need to be submitted to the Arbitration Commission, which will further communicate with the players involved in the appeal. If neither side needs to collect evidence or defense materials, go directly to the next step.
4. After the Chief Referee has accepted the appeal, Event Staff will invite Captain from both teams to meet in the Arbitration Room. Each team can only send three members to the Arbitration Room, and one must be either the Captain, OPM, key team member or Supervisor. The presence of the team Captain or the OPM is mandatory.
5. The Arbitration Commission makes a final decision. Both Captains sign the Appeal Form to confirm the decision. Once signed, both teams can no longer question the appeal result.
6. If a rematch has occurred for a round due to an arbitration decision requiring a “Rematch between Both Teams”, both teams can appeal again after the rematch. In this scenario, if the original appealing team appeals again (known as a “Continued Appeal”), the team’s opportunity to appeal

will be exhausted regardless of whether the appeal is successful. As a continued appeal will cause serious delays to the competition schedule, the continued appeal must be initiated together by both the team Captain and Supervisor within three minutes after the match ends (both signing on the Appeal Form at the same time).

The time for submission of evidence and materials is shortened to within 30 minutes of making the appeal. The RMOC will announce the outcome of the appeal on the Appeal Form within 60 minutes of the continued appeal being made.

8.2 Appeal Validity

Teams need to file an appeal within the validity period and below are different validity periods of different stages:

- **Appeal Request:** Appeals must be made within five minutes after the end of each match and recorded on the Appeal Form. The Arbitration Commission will not accept any appeal requests that exceeds the validity period.
- **Attendance to the Arbitration Room:** Both teams must arrive at the Arbitration Room within 30 minutes after receiving a notification from the Arbitration Commission. An absent team is deemed to give up its right to an appeal and must accept any decision made by the Arbitration Commission. If more than three members of a team enter the Arbitration Room or the identity of attendees do not meet the requirements, the team is also considered to give up their right to an appeal.
- **Submission of Evidence and Materials:** A team must submit evidence and materials within 60 minutes after requesting an appeal. The Arbitration Commission will not accept any new materials beyond this 60-minute limit.

8.3 Appeal Material

Appeal material that teams submit must follow the following specifications:

- **Types:** The Arbitration Commission only accepts materials stored on a USB drive or on a competing robot.
- **USB Drive:** The team must prepare video extracts and other document files as materials for their appeal. The RMOC will not assist in the collection of videos to maintain neutrality throughout the process.
- **Format:** Each video cannot exceed one minute in length be over 500 MB in size. The name of the video must indicate the specific round of the match and the time it was taken. Videos should be

compatible with the latest version of Windows Media Player, photos must be in JPG format, and text documents must be in Word format and not exceed 1,000 words in length.

- Name: The name of each video and photo must not exceed 30 characters.
- Text: Each text document can only refer to one video or photo and must clearly state the name of the video or photo being referred to. The text document only needs to reflect the specific rules violation in support of the photo/video/robot(s).
- Evidence of Robot: The Arbitration Commission has the authority to isolate any relevant robot from both teams after an appeal has been made. These robots will not be isolated for more than three hours and will be returned to teams when the appeal is adjudicated.

8.4 Appeal Decision

The Arbitration Commission will provide its final arbitration decision on the Appeal Form, which both team Captains must sign within an hour of the decision has been announced. If a team does not sign the Appeal Form, it is deemed to have accepted the appeal decision. The arbitration decisions that can be made include: Maintaining the original match results; a forfeiture issued against the respondent; a rematch between both teams. Neither team may appeal against the final decision of the Arbitration Commission.

If the Arbitration Commission requires both teams to hold a rematch, the Organizing Committee will inform both teams of the rematch time when the arbitration decision is announced. If both teams refuse to hold a rematch, the appeal is deemed failed and the original match results are maintained. If only one team refuses the rematch, the refusing team is deemed to have forfeited and lost the round.

Appendix 1 Safety Instruction

Every team and all its members of the RoboMaster 2020 Robotics Competition must fully understand and accept that safety is the most important issue for the sustainable development of the RoboMaster Robotics Competition. To protect the rights and interests of all those who participate in the competition, as well as the rights and interests of the event organizers, everyone who enters the RoboMaster 2019 Robotics Competition must make the following commitments, uphold and abide by the following safety clauses in accordance with applicable laws and regulations:

1. All participants shall state that they are fully capable of civil conduct and can independently manufacture and operate robots. Prior to using the robots made by the undertaking organization SZ DJI Technology Co., Ltd., all participants shall ensure they have carefully read relevant documents such as the Registration Guide and Rules of ICRA 2020 RoboMaster AI Challenge.
2. During the competition, all team members will ensure that their actions, including the manufacturing, testing, and use of robots will not cause any injury or damage to their teammates, members of the opposing team, staff, audience members, equipment or the Competition Area.
3. The team must ensure that the structural design of its robots will not hinder the safety inspections that take place prior to the commencement of the competition and agree to cooperate fully with the pre-inspection carried out by the RMOC.
4. The team guarantees that it will not use any internal combustion engines, explosives, use high-pressure gas as the working gas, or any dangerous materials.
5. Throughout the R&D, training as well as competition stage of the event, all team members must pay full attention to potential safety issues, and the team's Supervisor must be responsible for instructing and supervising the team on safety issues.
6. The team must guarantee the safety of all robots. This includes ensuring the projectile launcher installed on the robots is safe, and that it will not cause any harm either directly or indirectly to any operator, referee, event staff or audience.
7. The team will take sufficient and necessary safety measures during R&D, training, and competition stage of the event regarding any hazardous situations that may occur. This includes but is not limited to: preventing the control system from becoming unstable; anticipating every potential operation prior to carrying out the operation to avoid wrongful operation or a collision between team members or between robots and team members; prohibiting team members from engaging in solo training and making sure that one or more people have been appointed as an emergency responder; wearing goggles and helmets; properly applying the lock function in the robot control system before engaging in debugging or adjustments; and equipping an emergency stop function on all robots.

8. During practice and competition, all accident liabilities and corresponding losses caused by accidents such as robot failures will be shouldered by the teams.
9. The materials bought from or provided by the organizer of this competition (SZ DJI Technology Co., Ltd.) such as batteries and the Referee System must be used in accordance with the information contained in their user manuals. SZ DJI Technology Co., Ltd. will not be held responsible for any injuries that arise from the improper use of these materials. The team will be held responsible for any injuries caused to its own members or any other persons, as well as for damage caused to property arising from the production and operation of its robots.
10. All team members must remain in strict compliance with the laws and regulations of the People's Republic of China. All team members must also pledge that their robots will only be used for the RoboMaster competition and that their robots will not be illegally modified or used for any illicit purpose(s).

Appendix 2 Reference Drawings

Unit: mm

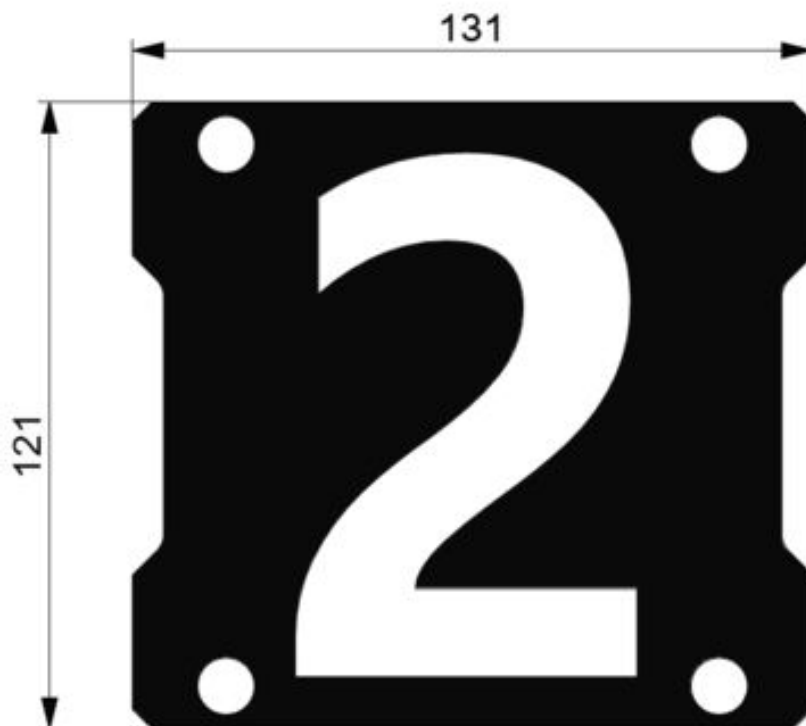
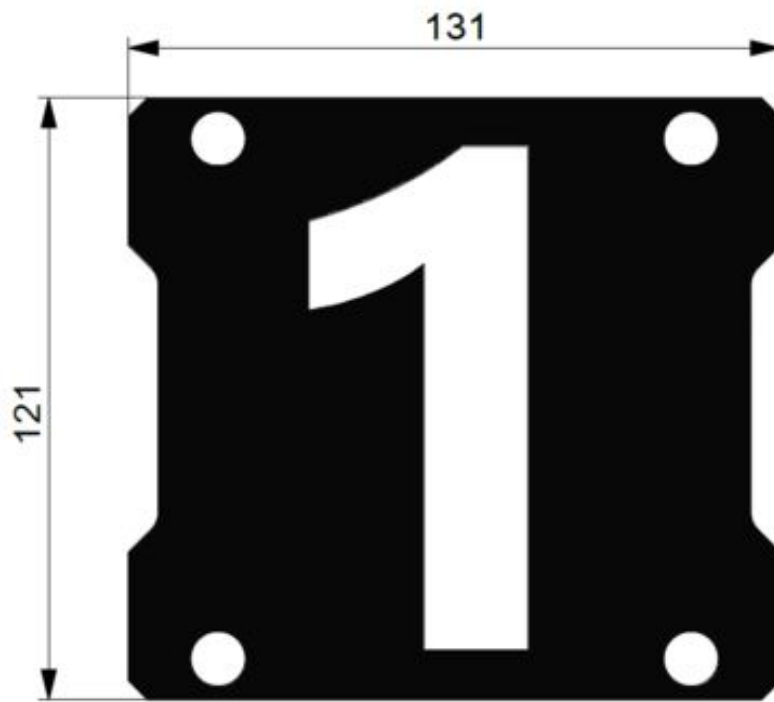

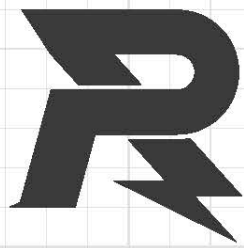

E-mail: robomaster@dji.com

Forum: bbs.robomaster.com

Website: www.robomaster.com

Tel: +86 (0)755 36383255 (UTC+8, 10:30AM-7:30PM, Monday to Friday)

Address: Room 202, Floor 2, Integrated Circuit Design & Application Industrial Park, No. 1089,
Chaguang Road, Xili County, Nanshan District, Shenzhen City, Guangdong Province, China